

PROJECT	QUANTITY	ITEM NO
---------	----------	---------

FlexFusion™ combi oven

Platinum

FPE 615 Electric
FPG 615 Gas
FlexiRack®



Chef's Touch control: Just tap and swipe to run automated cooking and operating apps

Henny Penny FlexFusion combi ovens combine different cooking methods into one piece of equipment with the flexibility to cook nearly everything on your menu to perfection.

The FlexFusion combi incorporates a powerful yet highly energy-efficient boilerless steam generation system that instantly adds or eliminates the precise amount of moisture needed to maintain desired cooking conditions... all while saving more energy and water than ever through an improved heat exchange design.

What really sets FlexFusion apart is its ease of use. The Platinum line features Chef'sTouch, an intuitive control system with a durable 7-inch touch/swipe screen that makes cooking with FlexFusion as easy as using a smart phone! Just tap the app for everything from cook-and-hold to cleaning and trouble-shooting.

Popular FlexFusion built-in Apps:

- **Cook and Hold**—Automatically switches to Hold when done cooking
- **Time-to-Serve**—Tells you when to load different items so they are all done at the same time
- **Family Mix**—Shows which items can be cooked together
- **Green Inside**—Displays energy and water use for each cooking program
- **Combi Doctor**—Runs system self-diagnostics and displays results

Core temperature probe and USB port are standard.

Removable tilt-resistant crosswise rails accept full-size steam table pans or FlexiRack pans and grids that offer additional capacity.

Standard Features

- Chef'sTouch™ Control System for Automatic or easy manual cooking
 - Durable 7-inch high resolution capacitive touch screen
 - Full-color touch/swipe display
 - Create and select from up to 350 custom cooking programs of 20 steps each
 - Select and use apps for cooking, serving convenience, cleaning, diagnostics and more
 - Adjust individual settings before or during cooking
 - Core temperature probe
 - Temperature in °F or °C
 - Choose language for operations and service diagnostics
- DynaSteam2 precision boilerless steam generation with built-in energy-saving heat transfer
- 5-speed auto-reverse fan for fast, even cooking throughout the cabinet
- Powerful high-efficiency motor uses up to 15% less energy
- Crosswise pan racking for better ergonomics
- Removable pan rack with tilt-resistant rails
- Improved WaveClean® self-cleaning system uses 36% less water
- Retractable spray hose for quick, easy rinsing of interior
- Filterless grease extraction
- 316S11 stainless steel interior cabinet with coved corners
- 1 mm stainless steel exterior
- Full perimeter door seal
- Energy efficient triple-pane glass
- Delayed start and preheat/cool down button
- USB port for convenient download of programs, diagnostic messages or HACCP data

Options, accessories*

- Multi-point temperature probe
- Barcode scanning app
- Stands and cabinets
- Stacking kit
- Chicken grids
- Alternate voltages

*See separate accessories data sheets for details

<input type="checkbox"/> APPROVED	<input type="checkbox"/> APPROVED AS NOTED	<input type="checkbox"/> RESUBMIT
AUTHORIZED SIGNATURE		DATE



PROJECT

ITEM NO

FlexFusion™ combi oven

Platinum

FPE 615 Electric
FPG 615 Gas
FlexiRack®

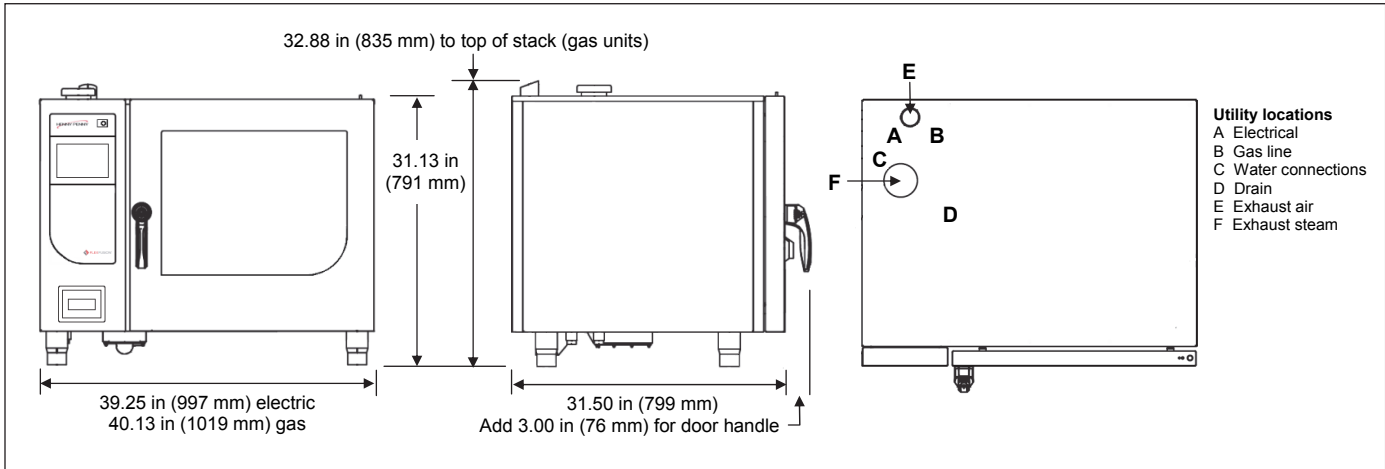

Dimensions

Height	31.13 in (791 mm) electric
	32.88 in (835 mm) gas
Width	39.25 in (997 mm) electric
	40.13 in (1019 mm) gas
Depth	31.50 in (799 mm)

Crated

Length	43 in (1080 mm)
Depth	38 in (960 mm)
Height	40 in (1020 mm)
Volume	38 ft ³ (1.1 m ³)
Weight	375 lb (170 kg)

Required clearances

Left	20 in (500 mm) service access
Right	2 in (50 mm) air flow
Back	2 in (50 mm) air flow, utilities
Front	28 in (700 mm) door open

Electrical

Volts	Phase	Hertz	kW	Amps	Wire
208	3	60	10.4	28.9	3+G
240	3	60	13.7	32.9	3+G
400	3	50/60	10.9	15.7	3NG

for gas units

120	1	60	0.8	3.9	1NG
230	1	50/60	0.8	2.0	1NG

Laboratory certifications



Heat (see also Cooking mode profiles)

Electric	Max temperature 572°F (300°C)
Gas	0.75 in gas line NPT external thread 37,500 BTU/hr or 11 kW/hr Max temperature 482°F (250°C)

Water

0.75 in standard cold water connection
0.75 in soft water connection
2.0 in (50 mm) drain

Capacity

- 6 full-size 2.5 in (65 mm) steam table pans crosswise
- 6 FlexiRack pans and grids
- 2 standard 6-chicken grids crosswise, 12 chickens per load
- 4 half-size FlexiRack 6-chicken grids, 2 per rail, 24 chickens per load

Cooking mode profiles

Steaming/moist heat	86-266°F (30-130°C)
Low and high temperature steaming	
Convection cooking/dry heat	86-572°F (30-300°C) electric
	86-482°F (30-250°C) gas
Active humidity reduction	
Combination/dry + moist heat	86-482°F (30-250°C)
	Manual or automatic humidity control between 0 and 100% RH
Rethermalizing/dry + moist heat	86-356°F (30-180°C)
	Special fan speed function, banqueting programs

Bidding specifications

Provide Henny Penny FlexFusion model FPE 615 electric or FPG 615 gas combi oven, designed to cook with steaming/moist heat, convection/dry heat, or a combination of dry and moist heat, and holding up to 6 full-size steam table pans crosswise or 6 FlexiRack pans or grids on removable tilt-resistant rails.

Unit shall incorporate:

- Chef's Touch Control System featuring protected full-color capacitive touch screen with automatic and manual cooking capability, and designated pre-loaded apps
- Boilerless DynaSteam2 Technology with precise 0-100% humidity control and heat exchange
- Variable speed, auto reverse fan that moves air in alternating directions for more even heating
- Automated WaveClean® self-cleaning system
- Seamless stainless steel cooking chamber, full-perimeter door seal and triple-pane glass for energy efficiency
- Cabinet interior: 316S11 stainless steel
cabinet exterior: 1 mm stainless steel

Continuing product improvement may subject specifications to change without notice.

24 Hour Technical Support:
 Henny Penny Technical Service
 800.417.8405
technicalservices@hennypenny.com

Henny Penny Corporation
 PO Box 60 Eaton OH 45320 USA
 +1 937 456.8400 800 417.8417
 +1 937 456.8434 Fax 800 417.8434 Fax
www.hennypenny.com

HENNY PENNY
 Engineered to Last