

# A600



## PRODUCT INFORMATION

The A600 is the new premium class of coffee machines, dramatically improving efficiency in professional use. The eight-inch color touchscreen with intuitive menu prompts and images entices customers to pick their espresso beverage of choice. Achieve additional sales through the easy placement of advertising messages and custom images on the display.

A milk processing system with temperature control delivers customized “barista” milk foam at exactly the right consistency - hot or cold, creamy or firm - in just seconds with the touch of a button. The double powder dosing system allows the use of two different powders (chocolates, chai, etc) and the optional flavor station with up to three flavored syrups enables the preparation of numerous types of drink specialties. The advanced integrated cleaning process reduces efforts to a minimum and provides clean, safe handling.

The A600 is the perfect solution for restaurants, convenience stores, quick-serve restaurants, schools, offices, and much more.

## FEATURES

- Intuitive touchscreen navigation on eight-inch panel
- 4 operating modes for efficient menu configuration
- Programmable milk quality and temperature settings for each product
- Variable foam consistency with hot or cold foam
- 2 x 2.5 lb bean hopper, lockable
- Milk container (1 G) with integrated temperature sensor and docking system
- Maximum energy efficiency
- Integrated cleaning process
- M2M/telemetry (coming soon)
- Professional installation and 1 year scheduled maintenance program available
- 12 months parts and labor warranty

*Make  
it  
Wonderful*

**FRANKE**

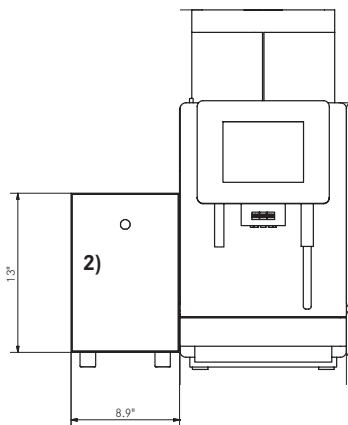
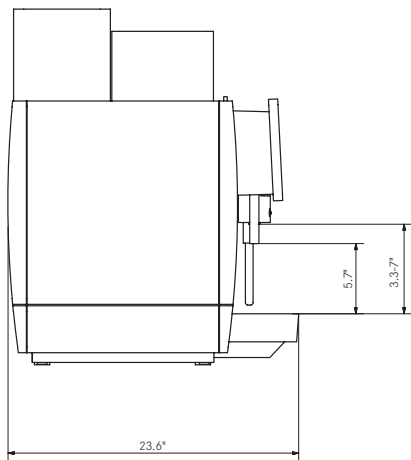
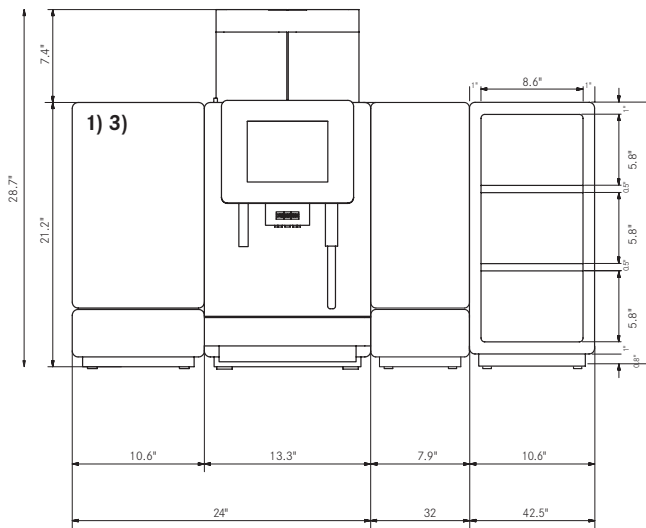

## PRODUCT SPECIALTIES

	A600 2 STEP	A600 MS	A600 FM
Ristretto   Espresso	✓	✓	✓
Coffee   Café crème	✓	✓	✓
Brewed coffee	✓	✓	✓
Cappuccino   Latte macchiato	(✓)	✓	✓
Chococcino	(✓)	✓	✓
Chocolate	✓	✓	✓
Hot milk	(✓)	✓	✓
Hot milk foam	(✓)	✓	✓*
Cold milk		✓	✓
Cold milk foam			✓*
Flavors			✓
Hot water   Steam	✓	✓	✓

\* Licensed by Thermoplan

( ) Non-standard features, added upon request

## MACHINE MODELS

MODEL	ELECTRICAL CONNECTION	POWER
A600	200-240V 2L PE 60 Hz 20-24A	3.6-5.4 kW
A600 MS	200-240V 2L PE 60 Hz 20-24A	3.6-5.4 kW
A600 FM	200-240V 2L PE 60 Hz 20-24A	3.6-5.4 kW

(other connection types upon request)

## ACCESSORIES

A600	ELECTRICAL CONNECTION	POWER
Cup warmer (120 cups)	110V 1LN PE 60 Hz 15A	130 W
A600 MS	ELECTRICAL CONNECTION	POWER
1) Refrigeration unit SU05 (1.3 G)	110V 1LN PE 60 Hz 15A	72 W
2) Refrigeration unit KE200 (1 G)	110V 1LN PE 60 Hz 15A	82 W
A600 FM	ELECTRICAL CONNECTION	POWER
3) Refrigeration unit SU05(1.3 G)	110V 1LN PE 60 Hz 15A	1,95-2,3 kW
Flavor Station (3 flavors)	110V 1LN PE 60 Hz 1.8A	25 W

## WATER CONNECTION

Fixed water connection	Metal hose with union nut G 3/8", l = 1,5m (59")
Water supply line	If possible on installation side: untreated water (not from household decalcification system)
Water pressure	80 to 800 kPa (0.8 to 8.0 bar)
Water hardness	3-5 GPG, 100 or less TDS
Total Chlorides	<30 mg/L
Ideal pH value	7

## WATER DRAIN

Drain hose	2 x 1" vented, 3/4" vented
------------	----------------------------

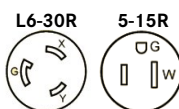

Franke Coffee Systems North America  
800 Aviation Parkway  
Smyrna TN 37167  
T + 1 877 379 3769  
www.frankeamericas.com

